

# **IRIDIUM SAVER**



DENSO has launched the latest generation of hardwearing spark plugs – the DENSO DOUBLE IRIDIUM (DDI) spark plug. DDI spark plug technology improves and extends the spark plug's lifespan and requires significantly less maintenance than competitor spark plugs. The DDI spark plug is particularly effective when used in biogas engines. Try DENSO DDI spark plugs today.

### Unique "Iridium alloy"

A unique, high welding point "Iridium alloy" developed and patented by DENSO, dramatically improves wear resistance compared to other Iridium plug.

Patent: Japan (2877035), UK (2302367), USA (6094000)

### Iridium Design

Iridium pads both on center electrode and on ground electrode, to minimize spark gap expansion.

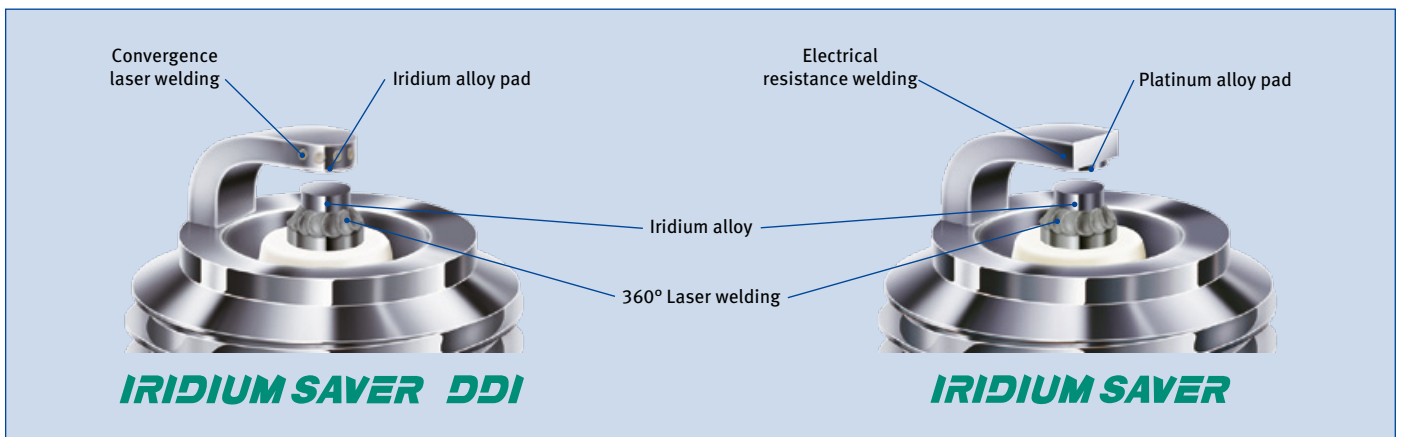

### Convergence laser welding

Wedge by laser welding fixes Iridium alloy pad on ground electrode securely, which realizes high reliability in high temperature combustion engine.

### 360° laser welding

Secure welding of the Iridium tip by "360° laser welding" can withstand all extreme engine conditions. Patent: Japan (2921524), USA (6078129)

### Proving longer life

Gap expansion is suppressed by Double Iridium Pads on both sides.

This suppression of gap expansion results in a longer life than Iridium Saver.

### Gap expansion

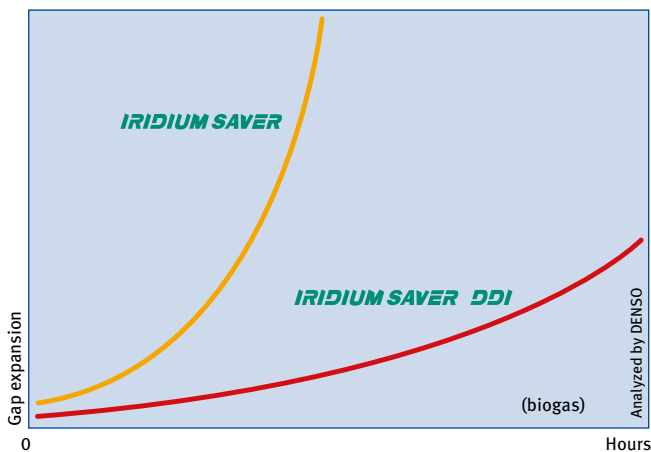

The above is analysed by DENSO

### Ignition Voltage limit

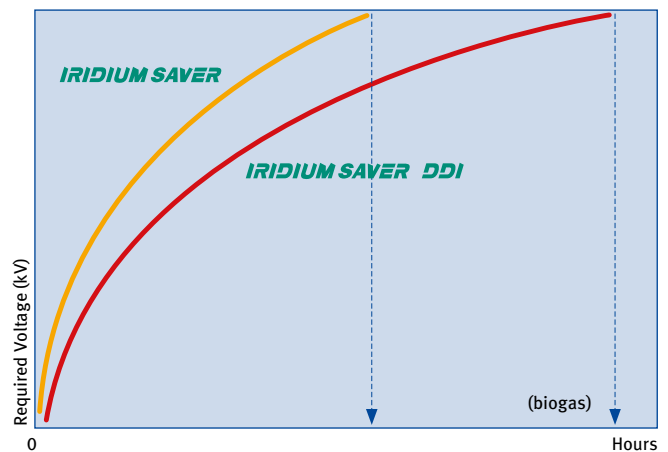

# Key to high reliability

## High Dielectric Ceramics

Newly developed ceramics with finer grain, molded-in higher pressure and higher density prevents electrical breakdown of insulator.

### Transverse Rupture Strength

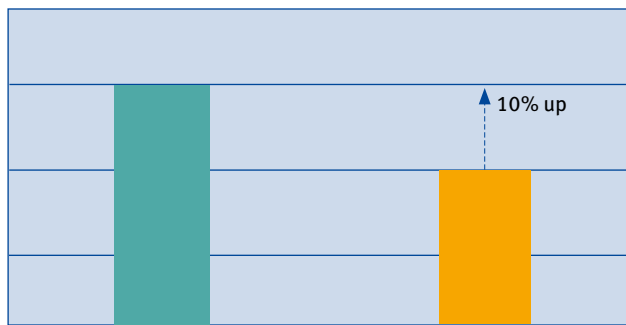

**IRIDIUM SAVER DDI**

Conventional Plug

### Electrical Breakdown Voltage (kV)

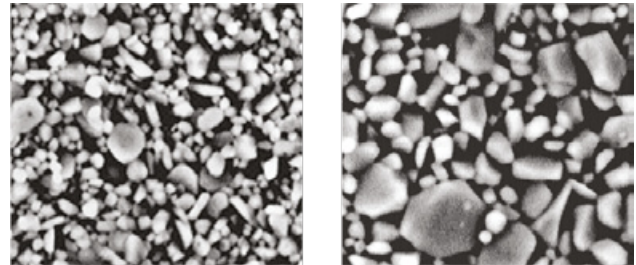

Newly Developed Ceramics

Conventional Ceramics

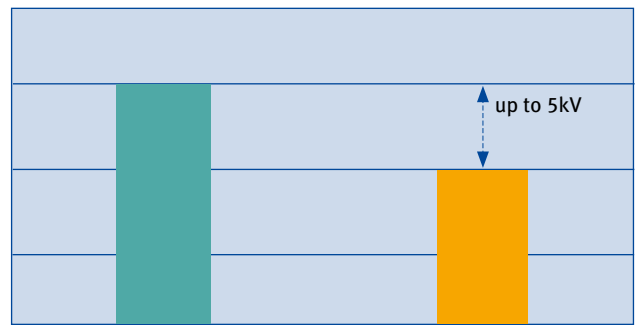

**IRIDIUM SAVER DDI**

Conventional Plug

## Highly Reliable Monolithic Resistor

The Iridium Saver Plug guarantees high reliability for withstanding high combustion pressures by incorporating a stress resistant monolithic resistor that adheres to the resistor glass in the high temperature furnace.

In addition, this eliminates interference to electronic equipment from high energy coil noise.

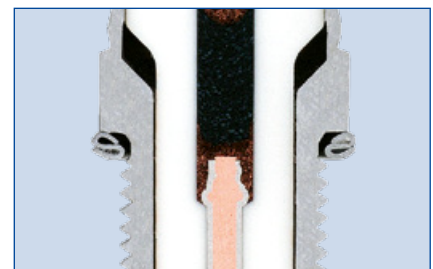

## IRIDIUM SAVER

## NORMAL PLUG

### Special Nickel Plating With Better Corrosive Resistance

Better corrosive resistance for condensed acid water. Exposure Test By Acid Steam Atmosphere.

Test length: 700 hours  
 Temperature: 90°C  
 Acid Water: pH=2



Analyzed by DENSO



Analyzed by DENSO

DENSO's OEM expertise and commitment to innovation enables them to remain at the forefront of cutting-edge gas engine spark plug development. The unique and specialist technology used in the Iridium Saver and Iridium Saver Performer spark plugs range extends their lifespan, making them ideal for high-compression lean-burn engines. Iridium Saver and Iridium Performer spark plugs also help to maximise engine performance and deliver extra durability. Because they require minimal maintenance compared to standard plugs, Iridium Saver and Iridium Saver Performer spark plugs increase service interval times. Try DENSO's Iridium Saver or Iridium Saver Performer spark plugs today.

## Unique "Iridium alloy"

A unique, high welding point "Iridium alloy" developed and patented by DENSO, dramatically improves wear resistance compared to other Iridium plug.

Patent: Japan (2877035), UK (2302367), USA (6094000)

## 360° laser welding

Secure welding of the Iridium tip by "360° laser welding" can withstand all extreme engine conditions.

Patent: Japan (2921524), USA (6078129)

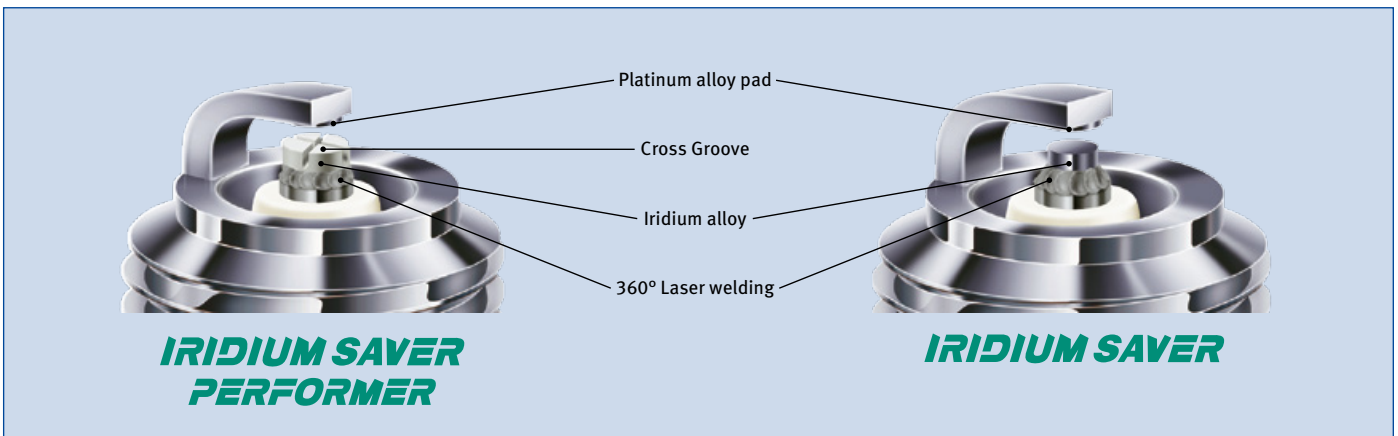

## Cross Groove design (M18 Spark Plug)

4 small electrodes created by Cross Groove improve sparking performance and suppress dispersion in voltage value, for an outstanding voltage decrease.

Patent: USA(6215234)

## Proving longer life

Required voltage is suppressed by 1) unique "Iridium alloy" 2) Cross Groove electrode, resulting in a longer life than conventional plug.

## The Cross Groove Design

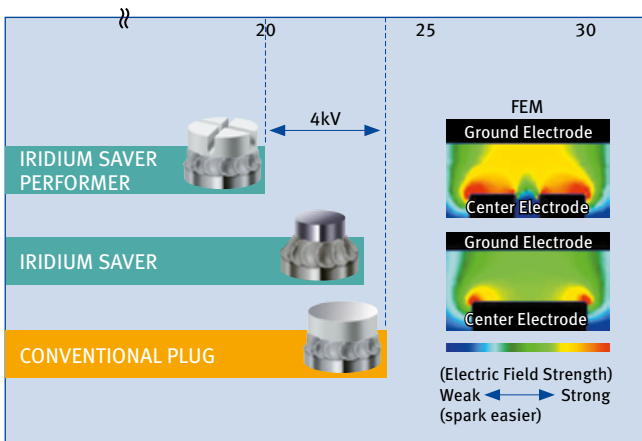

The above is analysed by DENSO

## Ignition Voltage Limit

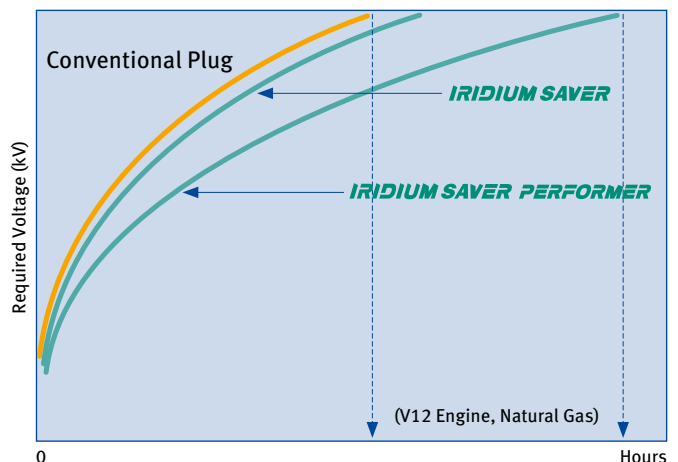

# Specifications and cross reference

**G** for Gas Engines | **I** | **3 - 1** | **(A)**

## Spark Plug Type and Installation Dimension

No	Thread	Hex Size	Reach
E	M 14 x 1.25	20.8 mm	19 mm
N			12.7 mm
K		16 mm	19 mm
L	M 18 x 1.5	20.8 mm	20.6 mm
I		22.2 mm	
T			13.8 mm

Initial Gap	
No	Normal Value
3	0.3 mm
4	0.4 mm
5	0.5 mm

Terminal Design	
No	SPEC.
none	solid
A	with nut

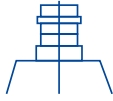

## Spark Plug Type and Installation Dimension

- IRIDIUM SAVER**  
Iridium pad without cross groove on center electrode and Platinum pad on ground electrode.
- IRIDIUM SAVER**  
For vehicle
- IRIDIUM SAVER DDI**  
Iridium pad without cross groove on center electrode and Iridium pad on ground electrode.



- IRIDIUM SAVER PERFORMER**  
Iridium pad with cross groove on center electrode and Platinum pad on ground electrode.
- IRIDIUM SAVER**  
Iridium pad without cross groove on center electrode and Platinum pad on ground electrode.
- IRIDIUM SAVER DDI**  
Iridium pad without cross groove on center electrode and Iridium pad on ground electrode.



## Cross Reference

	CHAMPION®	STITT®	ALTRONIC®	BERU®	IRIDIUM SAVER	IRIDIUM SAVER DDI	IRIDIUM SAVER PERFORMER
M14	RN79G (0.015)	407XL / R407XL	J1463DP	14R-3CPU / 14-3CPU / 14R-5DPU / 14R-4CDP	GE3-1	GE3-5	
	RN79G (0.020)			14R-4CIU (Z187) / 14R-4CIU2 (Z215) / 14R-4DIU2 (Z258) / 14R-4DIU3		GE3-5	
	RC78PYP / RC78PYP15			14FR-4DPUO	GK3-1	GK3-5	
	RC78WYP15			14FR-4DIU			
	RL85G / RL15B	407L / R407L	J1443DP	14R-5BPU / 14R-4ADP / 14R-5BIU	GN3-1		
M18	RB77WPCC / KB77WPCC / RB77CC / PB78WPC		L1863IP	18GZ4-77 / 18GZ6-77-2	GI3-3	GI3-5	GI3-1
	RB75N / RB75PP	R807LL	L1863B / L1863DP	18GZ20	GI3-3	GI3-5	GI3-1
	RB75WPCC-1			18GZ5-77-2	GL3-3	GL3-5	GL3-1
	RB76N / RB76PP	R807LL		18GZ7	GI3-3	GI3-5	GI3-1
	RM77N / RM77PP	807 / 827 / 847 / U827 / U847	L1843B / L1843IP	18GZ22			GT3-1

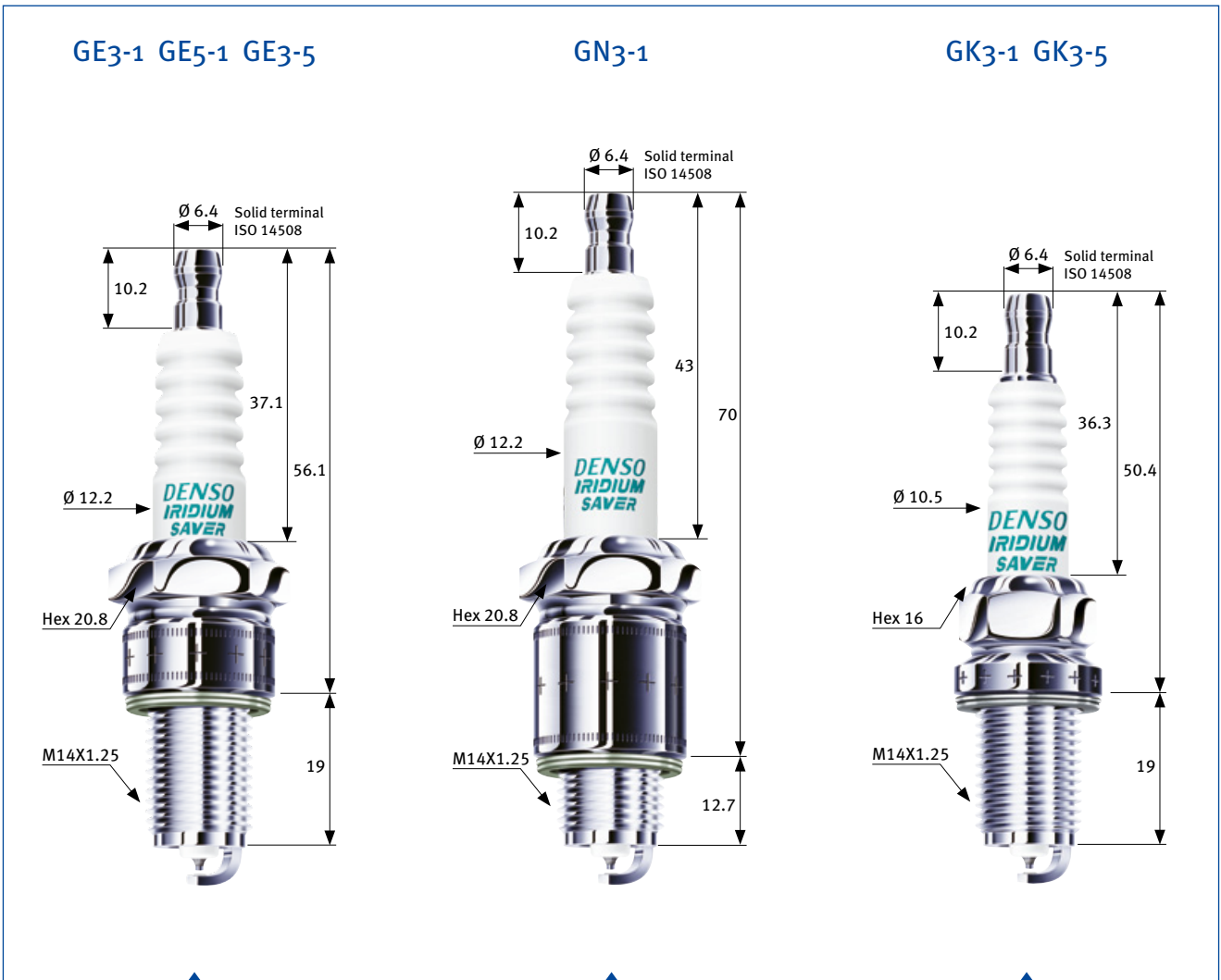

**IRIDIUM SAVER PERFORMER**



# Spark Plugs M18

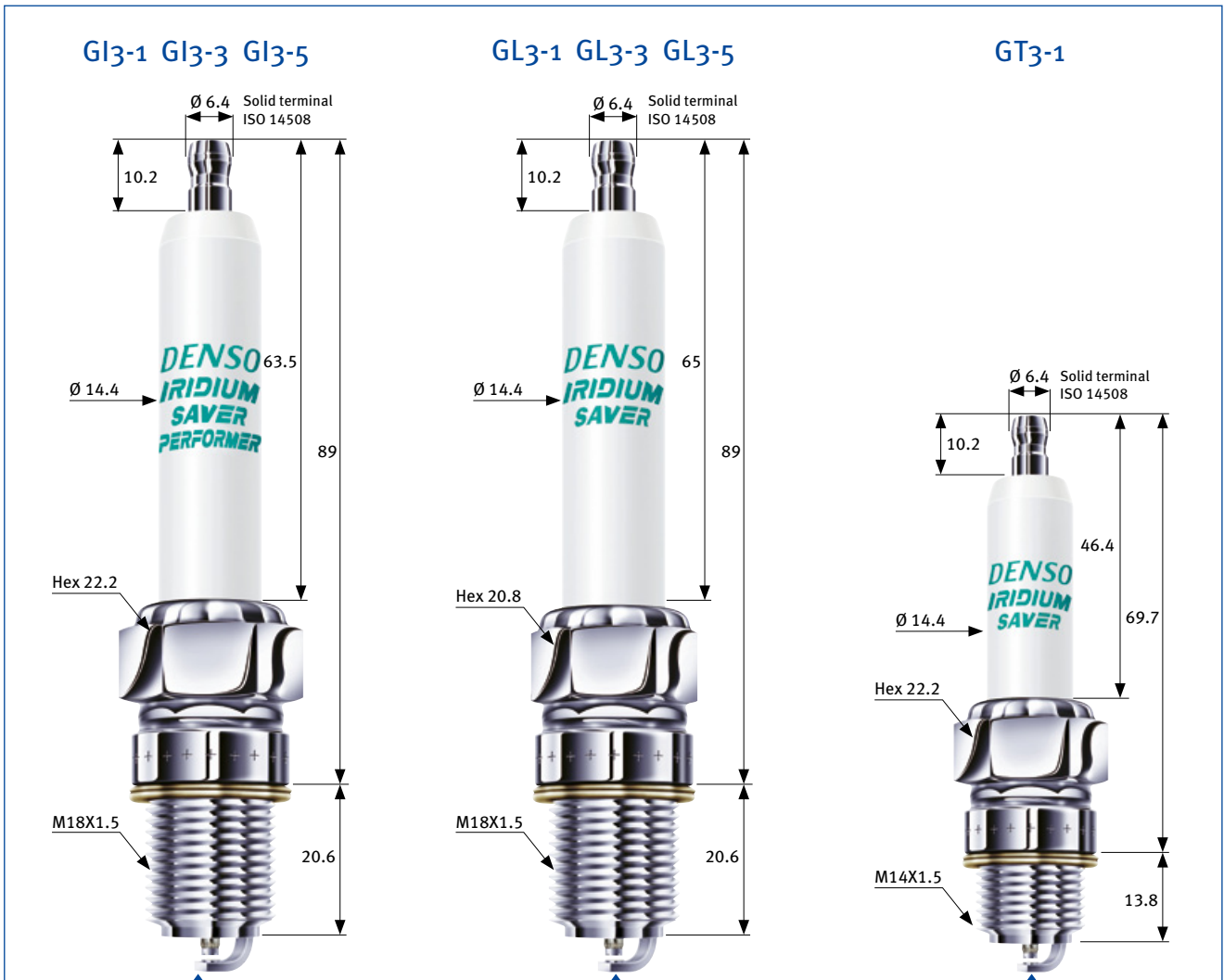

**IRIDIUM SAVER**



**IRIDIUM SAVER PERFORMER**



**IRIDIUM SAVER DDI**



## When things get hot our Service Team is at your site quickly.



Regardless of which part of the globe we need to travel to.

We know that the stakes are high, and therefore we outperform the others. That is because we want everything to run smoothly at your site, everywhere and at any time.



This is entirely in keeping up with our motto:  
Let us drop everything and work on your problem!



Distribution partner for DENSO spark plugs



### MOTORTECH GmbH

Hogrevestr. 21-23  
29223 Celle  
Phone: +49 5141 93 99 0  
Fax: +49 5141 93 99 99  
[www.motortech.de](http://www.motortech.de)  
[motortech@motortech.de](mailto:motortech@motortech.de)

### MOTORTECH Americas, LLC

1400 Dealers Avenue  
New Orleans, LA 70123  
Phone: +1 504 355 4212  
Fax: +1 504 355 4217  
[www.motortechamericas.com](http://www.motortechamericas.com)  
[info@motortechamericas.com](mailto:info@motortechamericas.com)

Distributed by:

#### Copyright

The copyright for all materials used in this MOTORTECH publication is reserved. Any kind of duplication or use of objects such as pictures or texts in other electronic or printed publications without approval by MOTORTECH is not permitted.

#### Trademark Information

All OEM names and part numbers shown are for reference purposes only. All trademarks, logos and symbols used or shown in this MOTORTECH publication are exclusive objects to the right of their owners and are used for reference purposes only.